

# Phylogenetic analysis of floral integration in *Schizanthus* (Solanaceae): does pollination truly integrate corolla traits?

F. PÉREZ,\* M. T. K. ARROYO\*† & R. MEDEL\*

\*Departamento de Ciencias Ecológicas, Facultad de Ciencias, Universidad de Chile, Santiago, Chile

†Instituto de Ecología y Biodiversidad, Facultad de Ciencias, Universidad de Chile, Santiago, Chile

## Keywords:

autonomous selfing;  
comparative studies;  
correlational selection;  
evolutionary constraints;  
modularity;  
phenotypic correlations;  
pollination.

## Abstract

To assess whether floral integration patterns result from the action of pollinator selection on functionally related traits, we compared corolla integration patterns in eight *Schizanthus* species differing in pollination systems and in their degree of pollinator dependence across a molecular phylogeny. Integration patterns differed among species and these differences were not related to their phylogenetic relatedness. When the putative original function of some corolla traits was lost in pollinator-dependent species, the integration among nonfunctional characters and the rest of the corolla traits was disrupted. This pattern was not presented in species adapted for late autonomous selfing, which exhibited higher corolla integration than their pollinator-dependent relatives. These results suggest that corolla integration in pollinator-dependent species was shaped by pollinator-mediated selection. Decoupling of nonfunctional traits in these species may result from a relaxation of correlational selection or from selection acting against a default covariation provided by genetic and developmental connections.

## Introduction

Phenotypic integration refers to the coordinated variation of morphological traits that result from genetic, developmental and functional relationships among traits (Cheverud, 1982; Murren, 2002; Pigliucci, 2003; Pigliucci & Preston, 2004). This tendency to vary in a coordinated fashion can be measured by the correlation structure of morphological traits within populations (e.g. Zelditch, 1988; Herrera *et al.*, 2002). The extent to which patterns of phenotypic integration reflect the action of natural selection keeping functionally traits linked or result from genetic and developmental constraints is a central question in evolutionary biology (Lande, 1979; Armbruster, 1996; Murren, 2002; Stepan *et al.*, 2002; Pigliucci, 2003; Armbruster *et al.*, 2004).

In animal-pollinated plants, the flower constitutes a complex reproductive structure that tends to covary independently of vegetative traits (Berg, 1960; Conner & Sterling, 1995; Armbruster *et al.*, 1999; Ashman & Maj-

etic, 2006). Floral integration and decoupling of floral traits from vegetative traits is thought to be the consequence of pollinator selection (Berg's, 1960 'correlation pleiades' hypothesis). Because a precise fit between flowers and pollinators is necessary to ensure pollination in plants with specialized morphology, phenotypic integration of floral traits that enhance pollination service is expected to increase through pollinator-mediated correlation selection (Stebbins, 1974; Conner & Via, 1993; Conner, 1997; Ushimaro *et al.*, 2003; Armbruster *et al.*, 2004; Anderson & Busch, 2006). Pollinator-mediated selection may simultaneously reduce the covariation of floral traits with vegetative traits when plants experience a reduced reproduction as a consequence of 'improper' pollen deposition in the pollinator body and flower stigma (Berg, 1960; Armbruster *et al.*, 1999). Notwithstanding, rather than reflecting solely the results of pollinator-mediated selection, integration among floral parts may also result from their development and spatial 'proximity' on the plant (Armbruster *et al.*, 1999, 2004; Herrera, 2001; Herrera *et al.*, 2002). For example, traits belonging to the same floral whorl are expected to exhibit high integration because they share developmental precursors and pathways (Conner & Sterling, 1995; Delph, 1996; Diggle, 2002).

*Correspondence:* Dra. Fernanda Pérez, Departamento de Ciencias Ecológicas, Facultad de Ciencias, Universidad de Chile, Casilla 653, Santiago, Chile.

Tel.: 562 9787438; fax: 562 2727363;  
e-mail: fefapt@yahoo.com

**Fig. 1** Schematic diagram of a *Schizanthus hookeri* flower and scanned images of the flattened corolla lips, showing the five measurements considered in this study. The following abbreviations are used throughout the text: B, banner; L, lateral section of upper lip; K, keel; W, wing; T, corolla tube.

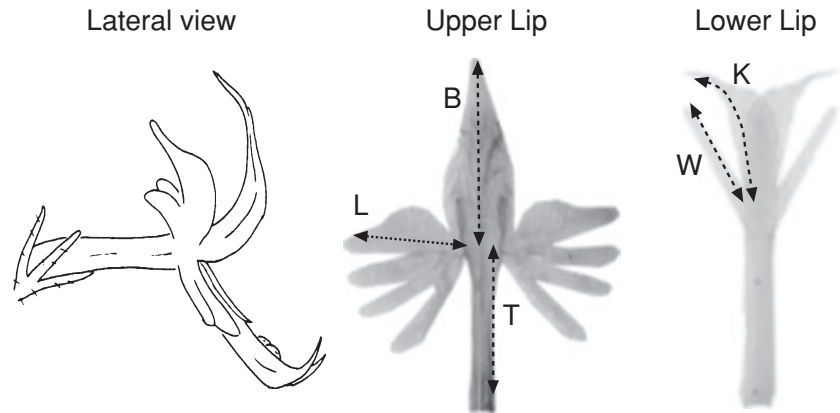

One way to examine the importance of pollinators on floral integration patterns is to compare the correlation structure of floral traits in phylogenetically related species that differ in their pollinator and breeding system, and in the functional role of floral traits for the pollination process. Here, we compare integration patterns of corolla traits across the phylogeny of the solanaceous genus *Schizanthus*. The genus *Schizanthus* comprises 12 species of annual herbs endemic to Chile and Argentina (Grau & Grönbach, 1984). The corolla of *Schizanthus* is strongly zygomorphic and bilabiate, resembling a papilionaceous flower (Fig. 1). Our previous work showed that diversification of flower traits in the genus occurred in response to selection by different groups of pollinators (Pérez *et al.*, 2006), thus making the genus a good candidate for comparing integration patterns across different pollinator selective scenarios. *Schizanthus* species currently differ in their pollination syndromes and flower visitors, which includes hummingbirds, bees, and lepidopterans as the most important pollinator taxa (Table 1). Mapping of pollination systems onto a molecular phylogeny revealed that the ancestral flower was probably bee-pollinated and that hummingbird and moth pollination were each acquired once along the phylogeny (Pérez *et al.*, 2006). As pollination systems changed, the putative original function of some corolla traits was lost.

Specifically, the lateral parts of the lower lip (wings) that were probably used as a landing platform in the bee-pollinated ancestor of the genus became reduced with the acquisition of hummingbird and moth pollination. In some cases, alternative floral structures have become used as a landing platform by insects, namely the inferior part of the lower lip (keel) or the stamens (Table 1). *Schizanthus* species also differ in their dependence on pollinators for seed set (Table 1), with some species being highly pollinator-dependent and others exhibiting a late autonomous selfing. In these species, selfing takes place late during anthesis as a result of elongation of the style that brings together the stigmas and dehiscent anthers (Pérez, 2004). Contrary to species where selfing takes place earlier during anthesis, the corolla of late-autonomous selfing species is neither reduced in size nor becomes closed (Kalisz *et al.*, 1999; Armbruster *et al.*, 2002), and thus it does not play an evident role in the self-fertilization process. Previous work has revealed that late autonomous selfing in the genus has probably evolved twice from pollinator-dependent ancestors (Pérez, 2004).

In this paper, we examine the role of pollinator-mediated selection on the evolution of corolla integration in *Schizanthus* species. More specifically, we predict that if pollinators increase corolla integration, (1) the overall

**Table 1** Characteristics of the *Schizanthus* species used in this study.

Species	PS	FV	BS	FS
<i>S. pinnatus</i>	B	B, D	PD	W: landing platform; K: retains stamens
<i>S. porrigens</i>	B	B	PD	W: landing platform; K: retains stamens
<i>S. tricolor</i>	B	B	PD	W: landing platform; K: retains stamens
<i>S. hookeri</i>	G	B, H, D	PD	K: landing platform, retains stamens; W: reduced
<i>S. integrifolius</i>	M	B, L	PD	W: reduced; K: reduced
<i>S. candidus</i>	M	None	A	W: reduced; K: reduced
<i>S. lacteus</i>	M	None	A	W: reduced; K: reduced
<i>S. grahamii</i>	H	H	A	W: reduced; K: reduced

PS, pollination syndrome: B, bee; H, hummingbird; M, moth. FV = flower visitors: B, bee; H, hummingbird; L, lepidopterans; D, dipterans. BS = breeding system: A, late autonomous selfing; PD, pollinator-dependent for seed set. FS = observed functions of wings (W) and keel (K) during pollination process. Data from Pérez (2004) and Pérez *et al.* (2006).

pattern of integration should differ among species with different pollinator and breeding systems, irrespective of their phylogenetic relatedness; (2) the level of integration of traits that have lost their functional role in the pollination process should decrease because of a putative relaxation of correlational selection; and (3) the acquisition of autonomous selfing mechanism should convey a lower level of corolla integration because species with autonomous selfing do not require pollinators for fertilization and the corolla has no obvious role on self-fertilization.

## Materials and methods

### Corolla integration

We studied corolla integration patterns in eight species of the genus *Schizanthus* (one population per species). The corolla of *Schizanthus* is strongly zygomorphic and bilabiate, consisting of five petals partially fused to form a narrow corolla tube (Fig. 1). The three uppermost petals constitute the upper lip, which in turn consists of a banner and two lateral sections. The two lowermost petals are deeply dissected. The inner portions of lower petals are fused to form a keel that in some species retains the stamens prior to explosive pollen discharge (Cocucci, 1989). The outer portions of the lower petals form the wings. Autonomous selfing levels (autofertility *sensu* Lloyd & Schoen, 1992) and flower visitors of the eight species of *Schizanthus* have been documented in Pérez (2004) and Pérez *et al.* (2006), respectively, for the same populations. Data on reproductive systems, pollination syndromes and flower visitors are summarized in Table 1. The functional role of the lobes of the lower lip differs among *Schizanthus* species (Table 1). Whereas in some species the wings are used as a landing platform, in others, the keel or the stamens perform this function.

One flower per each of 45–50 plants per population was collected in the field, preserved in 70% alcohol, and later dissected to separate the upper and lower lips to flat the corolla. The following five corolla traits were recorded from scanned images of the flattened flowers using SigmaScan Pro 5.0 (SPSS, 1998): banner length (*B*), length of the left lateral section (*L*), length of the left keel (*K*), length of the left wing of the lower lip (*W*), and the corolla tube length (*T*) (Fig. 1). All trait values were log-transformed before statistical analyses.

Pearson correlation coefficients among each pair of floral traits were calculated for each species and eight correlation matrices of  $5 \times 5$  were constructed. The corolla integration level (INT) was estimated from the variance of the eigenvalues of the corresponding correlation matrix (Wagner, 1984). As species differed in sample size, a corrected INT value was estimated as the difference between the observed integration value and an estimated value under the hypothesis of random covariation among floral traits (Wagner, 1984; see

Herrera *et al.*, 2002 for applications). The 95% confidence interval for each INT value was estimated through 1000 bootstrap simulations on the original log-transformed data (Cheverud *et al.*, 1989; Herrera *et al.*, 2002). An  $8 \times 8$  distance matrix (INTD) among the eight INT values was constructed, where each element corresponds to the absolute difference between INT values of each pair of species.

The pattern of significant correlation per species was depicted as correlation diagrams. To compare the integration patterns among species, we performed pairwise comparisons among the eight correlation matrices ( $8 \times 7 / 2 = 28$  comparisons) using Mantel (1967) tests (Cheverud *et al.*, 1989; see Baker & Wilkinson, 2003 for applications) in PopTools version 2.6.2 (Hood, 2004). An  $8 \times 8$  similarity matrix (SM) among correlation matrices was constructed, where each element corresponds to the correlation coefficient between the correlation matrices for each pair of species. To evaluate the overall pattern within *Schizanthus*, a binomial test was used. We determined whether the number of significant pairwise comparison was higher than the number expected by chance using  $\alpha < 0.05$  (see Baker & Wilkinson, 2003 for applications).

### Phylogenetic effects on integration patterns

To evaluate whether patterns of floral integration vary independently of phylogenetic relatedness, we mapped the correlation diagrams on a phylogenetic tree derived from the majority-rule-consensus tree recovered from the Bayesian analyses of DNA sequence data from three regions of all 12 *Schizanthus* (see Pérez *et al.*, 2006). The three species not studied in this paper were removed from the original phylogeny, with a new tree generated. An  $8 \times 8$  matrix of phylogenetic distances among the species was constructed (PHYD), with elements representing the sum of the branch lengths that separate each pair of species in the phylogeny. Correlation coefficients between PHYD and SM and between PHYD and INTD were calculated using the Mantel approach to test for significant phylogenetic effects in the correlation network and degree of integration (for applications see Steppan, 1997; Baker & Wilkinson, 2003).

### Loss of trait function and integration

To detect whether the level of integration between a particular trait and the remaining corolla traits decreases when the focal trait ceases to participate in pollination, we compared the ability of different functional models of integration to predict the covariation patterns in the five species that require pollinators for seed set. Models assume that pollination is the only cause of corolla integration. Therefore, the corolla lobes that participate in the pollination process constitute a unit of integration, whereas the other lobes should be

decoupled from the remaining floral traits. Based on the diversity of pollination mechanisms observed in *Schizanthus*, we compared three nested functional models. Model F1 represents the functional integration of the banner and lateral section of the upper lip. Model F2 represents the functional integration of the banner, lateral section, and wings. Model F3 represents the functional integration of all corolla lobes. We used confirmatory factor analyses to evaluate the goodness of fit of each model separately (Zelditch, 1987, 1988) using EQS version 6.1 (Bentler, 1985). We constructed factorial diagrams for each model incorporating one latent variable that summarizes the functional cause of covariation (Fig. 2). We also considered a null model of total independence among variables (nM). Because the null model and the three functional models are structurally nested ( $nM \subset F1 \subset F2 \subset F3$ ), and represent progressively less restricted and more complex models, we compared their goodness of fit with the  $\chi^2$  difference test (Bentler & Bonett, 1980). When the difference between nested models was not significant, the simplest

model was chosen. To avoid adopting unnecessarily complex models, we used  $\alpha = 0.005$  as recommended by Zelditch (1988). If floral integration results from pollinator-mediated selection, the covariation pattern of the three species using the banner to attract pollinators, wings as landing platform, and the keel to retain stamens prior to explosive pollen discharge (*S. porrigens*, *S. tricolor* and *S. pinnatus*) should fit better to model F3 because all the corolla lobes are functionally involved in the pollination process. Because the keel instead of wings is used as landing platform in *S. hookeri* (Table 1), this species is expected to fit better to model F2 as it decouples the wings from the rest of the corolla traits. Finally, because stamens instead of the keel or wings are used as landing platform in *S. integrifolius* (Table 1), the integration level shown by this species should fit better to model F1 as it decouples the keel and wings from the remaining corolla traits (in this species the stamens are not retained by the keel).

### Autonomous selfing and integration level

To evaluate whether the level of integration among corolla traits decrease with a decreasing level of pollinator dependence, we compared the INT values and their 95% confidence intervals of the autonomous selfing species with their immediate relatives that require pollinators for fertilization (Table 1). Two comparisons were carried out: (1) *S. grahamii* (autonomous selfing) vs. *S. hookeri* (pollinator-dependent) belonging to clade B, and (2) *S. lacteus* and *S. candidus* (autonomous selfing) vs. *S. integrifolius* (pollinator-dependent) belonging to clade C (Fig. 3).

## Results

### Corolla integration patterns

All INT values were  $> 0$ , indicating some level of integration of corolla traits in the eight species of *Schizanthus* (Table 2). The integration index INT ranged from 0.59 to 2.03, representing 12% to 41% of the maximum possible integration, respectively. We did not detect negative correlation coefficients among corolla traits (Fig. 3). Traits belonging to the superior lip showed a high and significant correlation ( $r_{B-L} > 0.8$ ) in every species. In contrast, traits shaping the lower lip were linked in some species but decoupled in others. Excepting *S. lacteus*, the corolla tube was decoupled from the lips in all species (Fig. 3). Paired comparisons among the correlation matrices of the eight *Schizanthus* species revealed a wide variation in phenotypic correlation structure within the genus (Table 3). Only 14 out of 28 comparisons showed a significant similarity. This proportion, however, was higher than expected by chance if there were no matrix similarity among species ( $P > 0.001$ ).

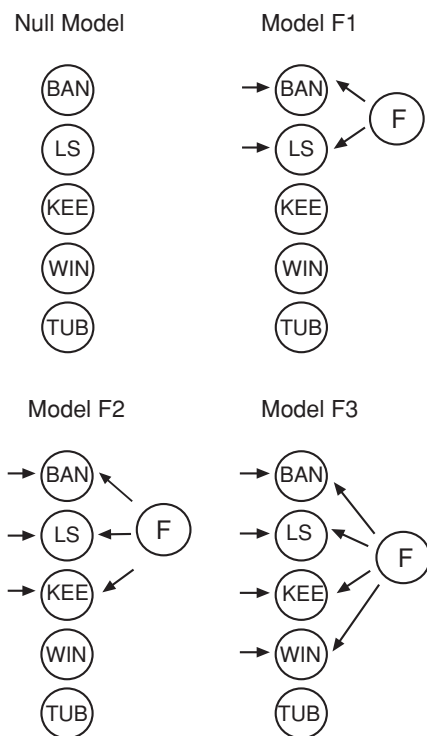

**Fig. 2** Path diagrams for three functional hypotheses representing the integration of corolla lobes that participate in the pollination process. Model F1 represents the functional integration of the banner and lateral section of the upper lip. Model F2 represents the functional integration of the banner, lateral section, and wings. Model F3 represents the functional integration of all corolla lobes. Circles represent the latent variable and squares represent observed variables. Arrows depict the direction of the causal influence. See Fig. 1 for a key to the abbreviations of the corolla traits.

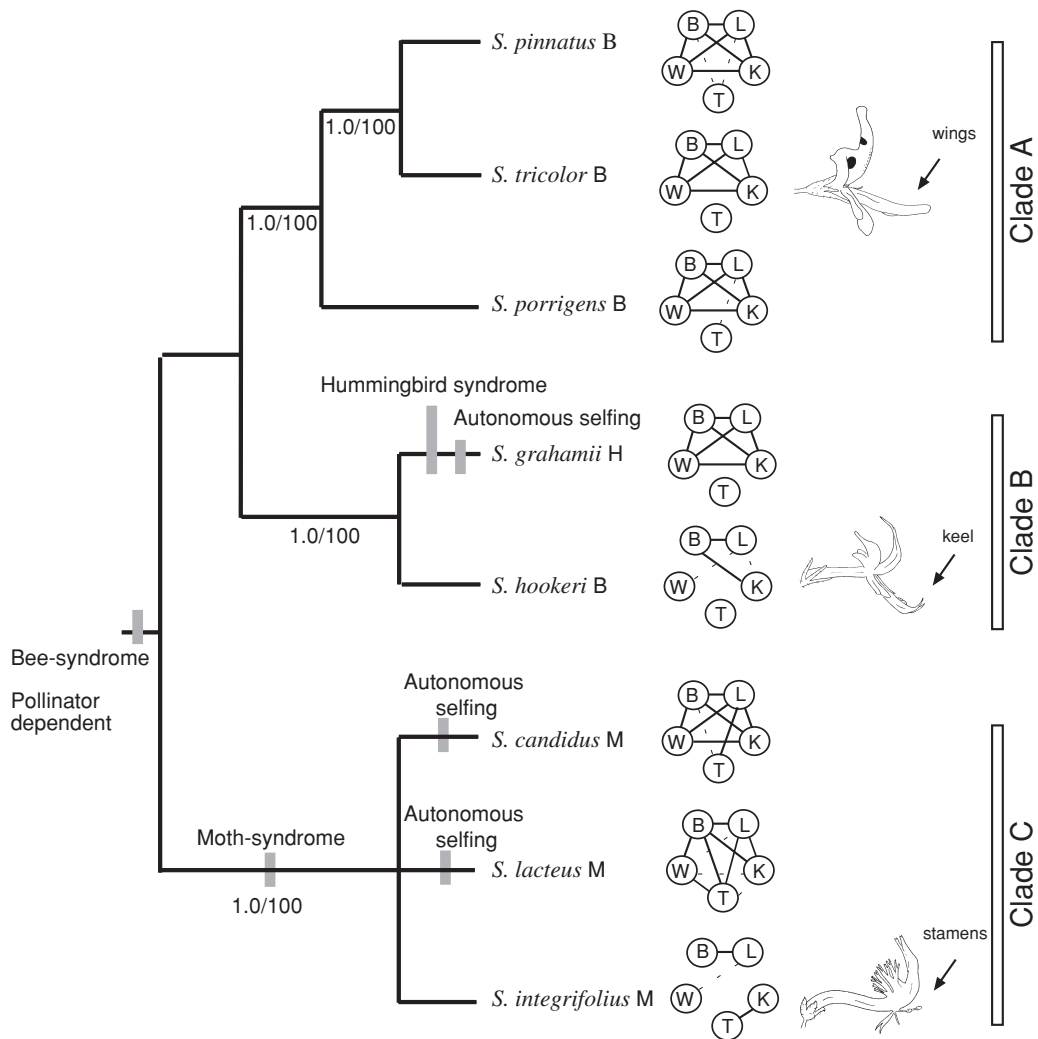

**Fig. 3** Correlation diagrams for the eight species mapped onto a part of the majority-rule-consensus tree recovered from the Bayesian analyses of all 12 *Schizanthus* species (Pérez *et al.*, 2006). Solid and dashed lines connecting two traits represent significant correlation coefficients higher than and lower than 0.5, respectively. All correlations were positive. In descending order, drawings represent the lateral view of flowers of *S. tricolor*, *S. hookeri* and *S. integrifolius*. Arrows indicate the floral trait that is used as landing platform. Reconstruction of ancestral states for pollination syndromes and breeding system are also shown (Pérez, 2004; Pérez *et al.*, 2006). Numbers below each branch tree are the Bayesian *a posteriori* probabilities/most parsimonious bootstraps for each clade > 50. See Fig. 1 for a key to the abbreviations of the corolla traits.

### Phylogenetic effects on integration patterns

The mapping of correlation diagrams onto the molecular phylogeny revealed a repeated correlation pattern in clade A (Fig. 3), which contains *S. pinnatus*, *S. tricolor*, and *S. porrigens*, species that share the same pollination and breeding systems. The similarity index among the correlation matrices of these species was > 0.9 in all cases (Table 3). The correlation diagrams were less conservative for clades B and C (Fig. 3), each of which contains species that differ in pollination and breeding systems. The similarity index between *S. hookeri* and *S. grahamii* (clade B) was 0.7, and among *S. integrifolius*, *S. candidus* and *S. lacteus* (clade C) lower than 0.5. The correlation

between the phylogenetic distance matrix (PHYD) with the similarity correlation matrix (SM) did not differ from zero ( $r = -0.09$ ,  $P = 0.270$ ). Similarly, the correlation between the PHYD and the integration distance matrix (DM) did not differ from zero ( $r = 0.12$ ,  $P = 0.150$ ). These results together indicate that phylogenetic relatedness had a low importance in determining the integration patterns across species.

### Loss trait function and integration

The integration pattern differed among the pollinator-dependent species of *Schizanthus* according to the variation in the functional relationships among corolla traits

**Table 2** Mean values of corolla traits and corolla integration levels in the *Schizanthus* species used in this study.

Species	B (cm)	L (cm)	K (cm)	W (cm)	T (cm)	INT (cm)
<i>S. candidus</i>	3.98	2.83	1.70	1.75	3.08	1.71 (1.42–2.07)
<i>S. grahamii</i>	4.46	3.28	2.75	2.53	1.36	1.61 (1.22–1.90)
<i>S. hookeri</i>	3.78	2.55	3.69	1.84	3.24	0.77 (0.56–1.14)
<i>S. integrifolius</i>	3.64	2.44	1.54	1.22	5.37	0.55 (0.42–0.91)
<i>S. lacteus</i>	2.78	1.89	1.16	0.50	1.70	1.62 (1.00–2.23)
<i>S. pinnatus</i>	2.56	1.65	1.92	2.37	0.68	1.58 (1.20–2.06)
<i>S. porrigens</i>	1.48	1.05	0.93	1.27	0.22	1.55 (1.18–1.96)
<i>S. tricolor</i>	1.50	1.17	0.98	1.27	0.28	1.34 (0.88–1.84)

Confidence intervals (95%) are indicated in parentheses. B, banner; L, lateral section of upper lip; K, keel; W, wing; T, corolla tube; INT, integration level.

**Table 3** Similarity matrix among correlation matrices of eight *Schizanthus* species.

	<i>S. pin.</i>	<i>S. por.</i>	<i>S. hoo.</i>	<i>S. gra.</i>	<i>S. int.</i>	<i>S. can.</i>	<i>S. lac.</i>
<i>S. tricolor</i>	0.95***	0.97***	0.53	0.94**	0.27	0.86**	-0.03
<i>S. pinnatus</i>		0.90**	0.57	0.89*	0.32	0.89**	-0.01
<i>S. porrigens</i>			0.54	0.93***	0.29	0.86**	-0.03
<i>S. hookeri</i>				0.72**	0.62**	0.67**	0.07
<i>S. grahamii</i>					0.37	0.85**	-0.08
<i>S. integrifolius</i>						0.49*	-0.10
<i>S. candidus</i>							0.12

Each element corresponds to the correlation coefficient between the correlation matrices for each pair of species. \* $P > 0.05$ , \*\* $P > 0.01$ , \*\*\* $P > 0.001$ .

**Table 4** Progressive evaluation of nested functional models relative to the null model of no integration in pollinator-dependent species of *Schizanthus*.

	Models				Comparisons		
	Null ( $\chi^2$ )	F1 ( $\chi^2$ )	F2 ( $\chi^2$ )	F3 ( $\chi^2$ )	F1 vs. Null ( $\Delta\chi^2$ )	F2 vs. MF1 ( $\Delta\chi^2$ )	F3 vs. F2 ( $\Delta\chi^2$ )
<i>S. porrigens</i>	179.3	122.0	87.1	48.5	57.3*	34.9*	38.6*
<i>S. pinnatus</i>	198.6	155.8	115.6	47.7	42.8*	40.2*	67.9*
<i>S. tricolor</i>	144.1	103.0	75.8	16.2	41.1*	27.2*	59.6*
<i>S. hookeri</i>	144.1	117.6	33.8	28.9	26.5*	83.8*	4.9
<i>S. integrifolius</i>	80.5	46.4	40.8	38.4	33.2*	5.6	2.4

Model F1 represents the functional integration of the banner and the lateral section of the upper lip. Model F2 represents the functional integration of the banner, the lateral section, and wings. Model F3 represents the functional integration of all corolla lobes. Chi-square values are indicated for null and functional models. \*Significant differences between nested models at the 0.005 level.

(Table 4). For *S. tricolor*, *S. pinnatus* and *S. porrigens*, the three species that use all the corolla lobes during pollination, the  $\chi^2$  values for the F3 model were significantly lower than the  $\chi^2$  values for the nested F1, F2 and null models. This result indicates that the covariance structure of the data for these species fits better to the model that represents the functional integration of all corolla lobes. This pattern was consistent with the correlation diagrams (Fig. 3) that show high and significant correlations among all the corolla lobes in these species. The covariance structure of *S. hookeri*, the species that uses the keel instead of the wings as the landing platform (Table 1), fitted better to the F2 model, that represents the functional decoupling of wings from the remaining corolla lobes (Table 4).

Even though the  $\chi^2$  value for F2 was lower than the  $\chi^2$  values for the nested F1 and null models, it was similar to the  $\chi^2$  value of the most complex F3 model. In this situation, the simpler F2 model was chosen. Data on *S. integrifolius*, the only species in the genus that uses stamens instead of keels or wings as the landing platform, fitted better to model F1 representing the functional decoupling of wings and keel. The more complex models F2 and F3 failed to improve the  $\chi^2$  values for the simplest F1 model in this species (Table 4). Overall, these results indicate that interspecific differences in integration patterns among pollinator-dependent species are consistent with differences in the function of floral traits during pollination. As expected, the degree of integration between a given trait and the rest of the

corolla traits decreased with a decreasing functionality of the trait in the pollination process.

### Autonomous selfing and integration level

The level of floral integration in the autonomous selfing species, *S. grahamii*, was twice as strong as in its pollinator-dependent relative, *S. hookeri* (1.61 vs. 0.77, respectively; Table 2). According to the nonoverlapping 95% confidence intervals, the degree of integration differed significantly between these two species (Table 2). Similarly, in clade C (Fig. 3) the two autonomous selfing species, *S. candidus* and *S. lacteus*, showed a significantly higher level of floral integration than their respective pollinator-dependent relative, *S. integrifolius* (1.71, 1.62 and 0.55, respectively; Table 2). Interestingly, and contrary to expectation, these results suggest that the level of corolla integration in *Schizanthus* tend to increase with decreasing pollinator dependence.

### Discussion

Our results revealed a wide variation in corolla integration patterns that was not correlated with phylogenetic distance among *Schizanthus* species. This result agrees with numerous studies performed in a broad range of organisms that have failed to detect a phylogenetic signal in patterns of phenotypic integration (e.g. Steppan, 1997; Pigliucci *et al.*, 1999; Marroig & Cheverud, 2001; Steppan *et al.*, 2002; Baker & Wilkinson, 2003), and indicates that lability of corolla integration patterns in *Schizanthus* is not the result of genetic drift (see Herrera *et al.*, 2002). The observation that corolla integration patterns were more conservative in the clade with species sharing pollination and breeding systems (clade A) than in the two more heterogeneous clades (B and C) is consistent with the idea that pollinator-mediated selection has played an important role in corolla integration in this group.

Integration patterns differed among pollinator-dependent *Schizanthus* species according to differences in the pollination mechanism, and the involved functional relationships among corolla traits. When the putative original function of the wings and/or keel is lost along lineages, integration of these traits with the rest of the corolla is disrupted. This phenomenon is not restricted to *Schizanthus* species. Decoupling of nonfunctional from functional floral traits has also been reported in other plant species (Kudoh *et al.*, 2001; Ushimaro *et al.*, 2003). For example, in the andromonoecious species *Commelina communis*, the perfect flowers have a higher anther-stigma correlation than the staminate flowers with vestigial female organs rarely involved in pollination (Ushimaro *et al.*, 2003).

The decoupling of the corolla traits that lost its function during pollination in *S. hookeri* and *S. integrifolius* could be attributed to the relaxation of correlation pollinator-mediated selection (see also Thompson *et al.*,

1998; Anderson & Busch, 2006). Recently, Anderson & Busch (2006) have suggested that relaxed correlational selection may be responsible for the weak stamen–petal and pistil–petal correlations shown by two independently derived self-compatible species of *Leavenworthia* as compared to their respective self-incompatible sister species.

The decoupling of nonfunctional traits from the rest of the corolla in *S. hookeri* and *S. integrifolius* may also result from pollinator-mediated selection acting against covariation. This pattern is analogue to Berg's (1960) 'correlation pleiades' hypothesis, but operate at different level. According to Berg's hypothesis, strong selection in specialized pollination flowers should favour both the phenotypic integration among floral parts and the decoupling of floral from vegetative traits. Thus, a high covariation among floral and vegetative traits would be the default situation, i.e. species that do not experience strong pollinator selection should have a high phenotypic correlation between floral and vegetative traits, which is disrupted at increasing flower specialization (see also Armbruster *et al.*, 1999, 2004). In the case of *Schizanthus*, integration and decoupling between functional and nonfunctional traits may occur within the corolla whorl. As in Berg's hypothesis, covariation among all corolla traits might be the default situation, i.e. species that do not experience strong pollinator selection, should have a high integration between functional and nonfunctional traits provided by genetic and developmental connections (Delph, 1996; Diggle, 2002; Herrera *et al.*, 2002).

Comparison of integration levels between the autonomous selfing species and their pollinator-dependent relatives indicate that in spite of their reduced wings and/or keel, selfing species showed a higher corolla integration than their counterparts. At least three nonmutually exclusive explanations can account for this pattern. First, if high covariation among corolla traits is the 'default' situation in this group, the low pollinator-mediated selection experienced by these species may have not been sufficient to disrupt the high integration between functional and nonfunctional traits provided by genetic and developmental connections. Second, it is known that inbreeding can change directly the genetic variance, covariance and correlation (Kelly, 1999; Whitlock & Fowler, 1999). Genetic correlations due to linkage disequilibrium are more likely to persist in inbred than outcrossed populations because inbreeding reduces the efficiency of recombination (Kelly, 1999). In addition, correlation among loci may occur when individuals vary in the extent to which they are inbred (Kelly, 1999). This situation is expected to occur in late autonomous selfing species, because they tend to exhibit intermediate selfing rates (Kalisz *et al.*, 2004). Third, an unexpected intensification of correlational pollinator selection in the autonomous selfing species derived from the specialization of pollination systems may account for the higher corolla integration. As shown in Table 1, the pollinator-

dependent *S. hookeri* and *S. integrifolius* are visited by a broader spectrum of pollinators than their autonomous-selfing relatives. According to Berg (1960), plants with generalized pollination systems have a weaker coupling among floral traits than plants with more specialized pollination systems because they do not require a precise fit between flower and visitors (see also Stebbins, 1974; Conner & Via, 1993; Armbruster *et al.*, 1999). This explanation, however, account partially for the observed pattern. Although generalization in pollinator-dependent species (*S. hookeri* and *S. integrifolius*) would explain the disintegration of all corolla traits, it does not explain why only a decoupling of nonfunctional traits occurs.

In summary, the analysis of integration patterns provides support to the hypothesis that corolla integration is shaped by pollinator-mediated selection in *Schizanthus*. This conclusion is supported by two observations. First, integration patterns in *Schizanthus* species were variable and independent of their phylogenetic relatedness. Second, the level of integration of *S. integrifolius* and *S. hookeri*, two pollinator-dependent species with traits that lost their functional role in the pollination process, was lower than the integration shown by species that retained trait functionality. This pattern occurred as a consequence of the decoupling of nonfunctional from functional traits rather than from an overall reduction in the magnitude of trait correlations among all characters. Trait decoupling may result from a relaxation of correlational pollinator-mediated selection or from pollinator-mediated selection acting against a default covariation provided by genetic and developmental connections.

## Acknowledgments

We thank Juan Armesto, Ana María Humaña, María de la Luz Trautmann and Santiago Pérez for their help in different stages of this work, and CONAF for permission to work in the Chilean National System of Protected Areas. This research was funded by grants FONDECYT 2010023 to FP and ACT 34/2006 to RM. FP thanks a fellowship from the Center for Advanced Studies in Ecology and Research in Biodiversity (PO2-051-F ICM).

## References

- Anderson, I.A. & Busch, J.W. 2006. Relaxed pollinator-mediated selection weakens floral integration in self-compatible taxa of *Leavenworthia* (Brassicaceae). *Am. J. Bot.* **93**: 860–867.
- Armbruster, W.S. 1996. Causes of covariation of phenotypic traits among populations. *J. Evol. Biol.* **9**: 261–276.
- Armbruster, W.S., Di Stilio, V.S., Tuxill, J.D., Flores, T.C. & Velásquez, J.L. 1999. Covariance and decoupling of floral and vegetative traits in nine Neotropical plants: a re-evaluation of Berg's correlation-pleiades concept. *Am. J. Bot.* **86**: 39–55.
- Armbruster, W.S., Mulder, C.P.H., Baldwin, B.G., Kalisz, S., Wessa, B. & Nute, H. 2002. Comparative analysis of late floral development and mating-system evolution in tribe Collinsieae (Scrophulariaceae). *Am. J. Bot.* **89**: 37–49.
- Armbruster, W.S., Pelabon, C., Hansen, T.F. & Mulder, C.P.H. 2004. Floral integration, modularity, and accuracy: distinguishing complex adaptations from genetic constraints. In: *Phenotypic Integration: Studying the Ecology and Evolution of Complex Phenotypes* (M. Pigliucci & K. Preston, eds), pp. 23–49. Oxford University Press, New York.
- Ashman, T.L. & Majetic, C.J. 2006. Genetic constraints on floral evolution: a review and evaluation of patterns. *Heredity* **96**: 343–352.
- Baker, H.G. & Wilkinson, G.S. 2003. Phylogenetic analysis of correlation structure in stalk-eyed flies (*Diasemopsis*, Diopsidae). *Evolution* **5**: 87–103.
- Bentler, P.M. 1985. *Theory and Implementation of EQS: A Structural Equation Program*. BMDP Statistical Software, Los Angeles, CA.
- Bentler, P.M. & Bonett, D.G. 1980. Significance test and goodness of fit in the analysis of covariance structures. *Psychol. Bull.* **88**: 588–606.
- Berg, R.L. 1960. The ecological significance of correlation pleiades. *Evolution* **17**: 171–180.
- Cheverud, J.M. 1982. Phenotypic, genetic and environmental morphological integration in the cranium. *Evolution* **36**: 499–516.
- Cheverud, J.M., Wagner, G.P. & Dow, M.M. 1989. Methods for the comparative analysis of variation patterns. *Syst. Zool.* **38**: 201–213.
- Cocucci, A. 1989. El mecanismo floral de *Schizanthus*. *Kurtziana* **20**: 113–132.
- Conner, J.K. 1997. Floral evolution in wild radish: the roles of pollinators, natural selection, and genetic correlations among traits. *Int. J. Plant Sci.* **158**: S108–S120.
- Conner, J.K. & Sterling, A. 1995. Testing hypotheses of functional relationships: a comparative survey of correlation patterns among floral and vegetative traits in five insect-pollinated plants. *Am. J. Bot.* **82**: 1399–1406.
- Conner, J.K. & Via, S. 1993. Patterns of phenotypic and genetic correlations among morphological and life-history traits in wild radish, *Raphanus raphanistrum*. *Evolution* **47**: 704–711.
- Delph, L.F. 1996. Flower size dimorphism in plants with unisexual flowers. In: *Floral Biology: Studies on Floral Evolution in Animal-Pollinated Plants* (D. G. Lloyd & S. C. H. Barrett, eds), pp. 241–273. Chapman & Hall Press, New York.
- Diggle, P.K. 2002. A developmental morphologist's perspective on plasticity. *Evol. Ecol.* **16**: 267–283.
- Grau, J. & Grönbach, E. 1984. Untersuchungen zur Variabilität in der gattung *Schizanthus* (Solanaceae). *Mitt. Bot. München* **20**: 111–203.
- Herrera, C.M. 2001. Deconstructing a floral phenotype: do pollinators select for corolla integration in *Lavandula latifolia*? *J. Evol. Biol.* **14**: 574–584.
- Herrera, C., Cerda, X., García, B., Guitián, J., Medrano, M., Rey, P. & Sánchez-Lafuente, A. 2002. Floral integration, phenotypic covariance structure and pollinator variation in bumblebee-pollinated *Helleborus foetidus*. *J. Evol. Biol.* **15**: 108–121.
- Hood, G.M. 2004. PopTools version 2.6.2. Available at <http://www.cse.csiro.au/poptools>.
- Kalisz, S., Vogler, D., Fails, B., Finer, M., Shepard, E., Herman, T. & Gonzales, R. 1999. The mechanism of delayed selfing in *Collinsia verna* (Scrophulariaceae). *Am. J. Bot.* **86**: 1239–1247.
- Kalisz, S., Vogler, D.W. & Hanley, K.M. 2004. Context-dependent autonomous self-fertilization yields reproductive assurance and mixed mating. *Nature* **430**: 884–887.

- Kelly, J.K. 1999. Response to selection in partially self-fertilizing populations. II. Selection on multiple traits. *Evolution* **53**: 350–357.
- Kudoh, H., Sugawara, T., Wu, S. & Murata, J. 2001. Morph-specific correlations between floral traits in a distylous *Ophioriza nipoensis* (Rubiaceae) population in southern China. *J. Trop. Ecol.* **17**: 719–728.
- Lande, R. 1979. Quantitative genetic analysis of multivariate evolution applied to brain: body size allometry. *Evolution* **33**: 402–416.
- Lloyd, D.G. & Schoen, D.J. 1992. Self- and cross-fertilization in plants. I. Functional dimensions. *Int. J. Plant Sci.* **153**: 358–369.
- Mantel, N. 1967. The detection of disease clustering and a generalized regression approach. *Cancer Res.* **27**: 209–220.
- Marroig, G. & Cheverud, J.M. 2001. A comparison of phenotypic variation and covariation patterns and the role of phylogeny, ecology, and ontogeny during cranial evolution of New World monkeys. *Evolution* **55**: 2576–2600.
- Murren, C.J. 2002. Phenotypic integration in plants. *Plant Species Biol.* **17**: 89–99.
- Pérez, F. 2004. *Evolución de la integración floral en el género Schizanthus (Solanaceae) en asociación a los sistemas de polinización y reproducción*. PhD Thesis, Universidad de Chile, Santiago, Chile.
- Pérez, F., Arroyo, M.T.K., Medel, R. & Hershkovitz, M. 2006. Ancestral reconstruction of flower morphology and pollination systems in *Schizanthus* (Solanaceae). *Am. J. Bot.* **93**: 1029–1038.
- Pigliucci, M. 2003. Phenotypic integration: studying the ecology and evolution of complex phenotypes. *Ecol. Lett.* **6**: 265–272.
- Pigliucci, M. & Preston, K. 2004. *Phenotypic Integration: Studying the Ecology and Evolution of Complex Phenotypes*. Oxford University Press, Oxford.
- Pigliucci, M., Cammel, K. & Schmitt, J. 1999. Evolution of phenotypic plasticity: a comparative approach in the phylogenetic neighborhood of *Arabidopsis thaliana*. *J. Evol. Biol.* **12**: 779–791.
- SPSS. 1998. *Sigma Scan Pro 5.0*. SPSS Science, Chicago, IL.
- Stebbins, G.L. 1974. *Flowering Plants: Evolution Above the Species Level*. Harvard University Press, Cambridge.
- Steppan, S.J. 1997. Phylogenetic analysis of phenotypic covariance structure II. Reconstructing matrix evolution. *Evolution* **51**: 587–594.
- Steppan, S.J., Phillips, P. & Houle, D. 2002. Comparative quantitative genetics: evolution of the G matrix. *Trends Ecol. Evol.* **17**: 320–327.
- Thompson, F.L., Hermanutz, L.A. & Innes, D.J. 1998. The reproductive ecology of island populations of distylous *Menyanthes trifoliata* (Menyanthaceae). *Can. J. Bot.* **76**: 818–828.
- Ushimaro, A., Itayaki, T. & Ishi, H. 2003. Floral correlations in an andromonoecious species, *Commelina communis* (Commelinaceae). *Plant Species Biol.* **18**: 103–106.
- Wagner, G.P. 1984. On the eigenvalue distribution of genetic and phenotypic dispersion matrices: evidence for a non random organization of quantitative character variation. *J. Math. Biol.* **21**: 77–95.
- Whitlock, M.C. & Fowler, K. 1999. The changes in genetic and environmental variance with inbreeding in *Drosophila melanogaster*. *Genetics* **152**: 345–353.
- Zelditch, M.L. 1987. Evaluating models of developmental integration in the laboratory rat using confirmatory factor analysis. *Syst. Zool.* **36**: 368–380.
- Zelditch, M.L. 1988. Ontogenetic variation in patterns of phenotypic integration in the laboratory rat. *Evolution* **42**: 28–41.

Received 31 March 2007; accepted 23 May 2007